



Diaphragm seal MD 22 Compact version



Benefits

- Robust, compact stainless steel design
- Ideal for heavy fuel oil, suspensions and corrosive media
- Suitable for medium pressure ranges

Application

For mounting to Bourdon tube pressure gauges, pressure transducers or pressure switches. For corrosive, hot and polluted media at medium pressures. Specially suitable for mechanical engineering and chemical industry applications.

Versions

Process connection	Instrument connection	Nominal pressure	Minimum range* (in bar) at nominal size					Part no.
			63	100	160	DMU	DMU 13 Vario	
G $\frac{1}{4}$ B	Welded connection	PN 40	0.6 bar	0.6 bar	0.6 bar	0.6 bar	0.6 bar	31997W
G $\frac{1}{2}$ B	Welded connection	PN 40	0.6 bar	0.6 bar	0.6 bar	0.6 bar	0.6 bar	31998W
G $\frac{1}{4}$ B	Welded connection	PN 250	4 bar	4 bar	4 bar	4 bar	4 bar	32000W
G $\frac{1}{2}$ B	Welded connection	PN 250	4 bar	4 bar	4 bar	4 bar	4 bar	32001W
$\frac{1}{2}$ -14 NPT	Welded connection	PN 40	0.6 bar	0.6 bar	0.6 bar	0.6 bar	0.6 bar	31999W
$\frac{1}{2}$ -14 NPT	Welded connection	PN 250	4 bar	4 bar	4 bar	4 bar	4 bar	32002W



Blue part no. = in-stock items



Technical specifications

Process connection

Stainless steel 316 L

Fixed male thread G $\frac{1}{4}$ B, G $\frac{1}{2}$ B or $\frac{1}{2}$ -14 NPT

Diaphragm

Stainless steel 316 Ti/316 L

Internal, welded

Instrument connection

Welded connection

Pressure transmission liquid

Paraffin oil (FM 09), FDA-listed

Pressure range

See overview of versions

Nominal pressure

PN 40, PN 250

Options

- Adapter for instrument connection G $\frac{1}{4}$ B/G $\frac{1}{2}$ B
- Cooling element (> 100 °C)
- Capillary tube
- Other threads
- Other materials
- Other filling liquids

Technical drawings

Type MD 22

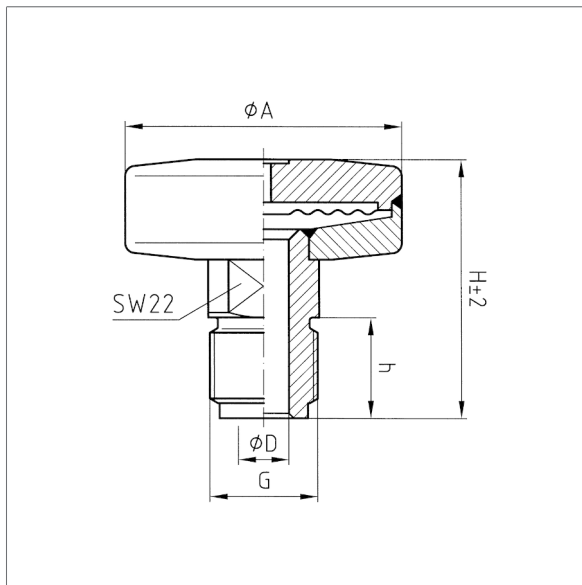

Adapter for instrument connection G $\frac{1}{4}$ /G $\frac{1}{2}$ with filling port

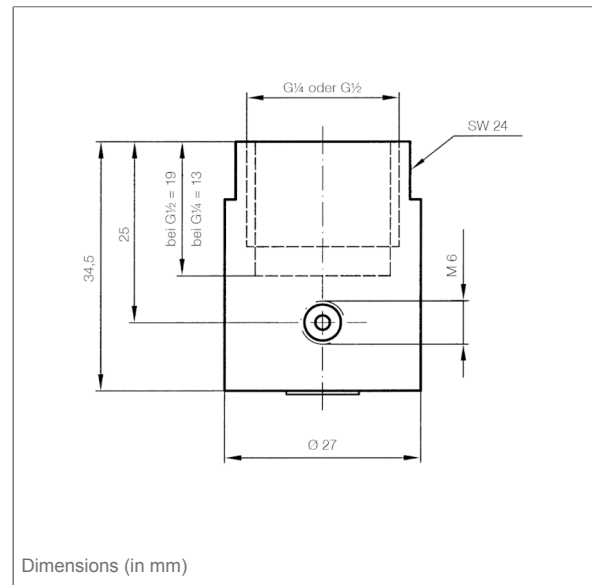

PN	G	ØA	ØD	h	H
40	G $\frac{1}{4}$ B	55	6	13	44,5
40	G $\frac{1}{2}$ B	55	6	16	47,5
40	G $\frac{1}{2}$ B	55	10	20	51,5
40	$\frac{1}{4}$ "NPT	55	6	15	46,5
40	$\frac{1}{2}$ "NPT	55	10	20	51,5
250	G $\frac{1}{4}$ B	40	6	13	44,5
250	G $\frac{1}{2}$ B	40	6	16	47,5
250	G $\frac{1}{2}$ B	40	10	20	51,5
250	$\frac{1}{4}$ "NPT	40	6	15	46,5
250	$\frac{1}{2}$ "NPT	40	10	20	51,5



Cooling element, can be welded at both ends

